



# Installation Instructions

## Dual Perimeter Plate Nitrous System (#82185)

Thank you for choosing ZEX™. If at any time you have questions regarding this or any of our products, please call our ZEXTEK™ support line at 1-888-817-1008.

Read this installation manual completely before attempting to install your nitrous system. Failure to do so may result in damage to your engine or vehicle and/or physical harm to yourself. ZEX™ is not responsible for damage or injuries caused by improper use of this nitrous kit.



**ZEX™ 3418 Democrat Road, Memphis, TN 38118**  
**ZEXTEK™ 1-888-817-1008**

ZEX171  
Revised 4/6/06

## Kit Parts List

<u>DESCRIPTION</u>	<u>QTY.</u>	<u>DESCRIPTION</u>	<u>QTY.</u>
Nitrous Solenoid	1	.067 N20/ Fuel Jet	2
Fuel Solenoid	1	.105 N20/ Fuel Jet	2
12" -4AN Hose, 3 AN nut, 1/8 NPT end	4	Arming Switch	1
16' Hose, -4AN, purple	1	Wide Open Throttle Switch	1
Perimeter Plate	2	Red 18 GA. Wire	15ft.
Carb Gaskets	4	Red 14 GA. Wire	15ft.
¼ NPT to -4 AN Filter Fitting	1	30amp Fuse Holder	1
¼ NPT to 3/8 Barb Fitting	1	30amp Fuse	1
1/8 NPT Male Tee Fitting	2	Bosch 20amp Mini Relay	1
10lb. Nitrous Bottle w/Valve	1	5/16-18 X 1" Bolt for Bottle Brackets	4
Bottle Bracket (short)	1	5/16 - 18 Nut for Bottle Brackets	4
Bottle Bracket (long)	1	5/16 - 24 Nut for Carb Studs	8
Solenoid / WOT Switch Bracket	3	5/16 Flat Washer	12
.043 N20/Fuel Jet	2	Solenoid Bracket Screws	4
.046 N20/ Fuel Jet	2	4-40 Socket Head Screws	2
.053 N20/ Fuel Jet	2	4-40 Lock Nuts	2
.056 N20/ Fuel Jet	2	Extended Carb Studs	8
.064 N20/ Fuel Jet	2		

## Why our nitrous system is better

- Fits all popular square flange 4-barrel, side-by-side carb, tunnel ram intake manifolds. Easy to install.
- Adjustable from 150-300 horsepower. Powerful enough for racing use, but easily jetted down for the street.
- Injects at 24 unique points surrounding the intake manifold plenum. Eliminates 30 year-old technology spray bars and optimizes distribution of fuel and nitrous into the engine.
- Cryogenic design flows super-chilled nitrous through the entire plate, before being sprayed into the engine. This creates a cooling “deep freeze” effect on the carburetor and intake manifold for additional power.
- The injector plate is machined from solid billet aluminum. This ensures precision flow, unlike cast plates and old-technology spray bars the competition uses.

## Quick Start Reference Guide

### **How the ZEX™ Dual Perimeter Plate Nitrous System works:**

The ZEX™ 82185 nitrous system begins with a connection to a supply cylinder containing pressurized liquid nitrous oxide and a connection to the engine’s fuel system. These connections go to the system's nitrous and fuel solenoids, respectively. These solenoids are normally closed, but are opened when the nitrous system is armed, and the throttle activation switch is activated by the carburetors going to wide-open throttle. Once these solenoids open, the nitrous and fuel are delivered to the injection plates via braided stainless steel delivery lines. The amount of nitrous and fuel that is injected through the plates is adjustable by means of metering jets installed in the plates themselves. These metering jets allow for easy changes in horsepower settings.

**Work safely:** Always wear eye protection and gloves when working with lines or hoses that contain pressurized nitrous oxide or fuel. Never transport nitrous cylinders loose behind a seat or in the back of a pick-up truck. Always disconnect the GROUND side of the battery when working on any electrical components.

**Nitrous oxide won't fix problems you already have:** Before you install your nitrous system, be sure your engine is in good mechanical condition. Intermittent wiring problems, etc., can lead to erratic system performance and possible engine damage.

**Never defeat operation of the safety relief disc in the nitrous cylinder's valve:** It's required by law and is there for your safety. Never drill, machine, weld, deform, scratch, drop, or modify a nitrous oxide tank in ANY way whatsoever!

**Never overfill nitrous cylinders:** That little bit extra will put you and others at risk of injury. More often than not, when the cylinder warms up, the pressure goes above the limit of the safety relief disc and you lose all the nitrous you just paid for.

**All the power comes from the fuel, not the nitrous:** Nitrous oxide is simply a tool that allows you to adjust how much and how quickly the engine burns the fuel. If the fuel isn't there, the power won't be either.

**Avoid detonation at all times:** Nitrous enhanced detonation is much more damaging than detonation that occurs when naturally-aspirated due to the increased amount of fuel available for releasing energy and the fact that more oxygen is present.

**When system is activated, if something doesn't feel or sound right, BACK OFF:** If you hear any detonation or feel anything unusual, get off the throttle. It's a lot easier to check everything over than it is to just try to drive through it and damage expensive parts. Don't activate or have the system activated when you hit the rev limiter.

**Do not use Teflon sealing tape on any fittings in a ZEX™ Nitrous System:**

It is easy for Teflon tape to get pulled into the system, causing blockages that can ultimately lead to incorrect nitrous system performance and potentially, engine damage. Only use liquid thread sealer for all NPT type fittings. Do not use any thread sealing compound on AN style fittings.

**Do not attempt to start engine if nitrous has been accidentally injected into the engine while it was not running:**

Disable the ignition and, with the throttle wide open, turn over the engine for several seconds to clear the nitrous from the engine. Failure to do this before restarting the engine can lead to a dangerous intake system backfire.

**Do not engage your nitrous system below 2500 rpm:**

This ensures that you will not have excessive cylinder pressures that could cause engine damage.

**When finished using your nitrous system, close the bottle valve and relieve line pressure:**

This eliminates the possibility that nitrous could inadvertently accumulate in the intake manifold while the nitrous system is not being used.

**Do Not Run Excessive Bottle Pressures:**

Excessive bottle pressures, over 1100 psi, are dangerous to your engine. Your ZEX™ nitrous system is calibrated and optimized to operate from 900-1000 psi. Exceeding this will not improve performance. Over 1100 psi also runs the danger of locking the nitrous solenoid closed due to excessive pressure working against the valve's plunger. If this happens, you must cool the nitrous bottle down to lower the pressure. This will allow the valve to operate properly.

## Start with the lowest horsepower setting and work your way up:

This ensures if you have any tuning issues to work out on your vehicle, they will get sorted out with a smaller shot of nitrous that will be less likely to damage your engine. Once you have the car working well on the smaller shot, you can then safely start to step up your nitrous kit horsepower.

## Make sure your vehicle has an adequate fuel supply:

Nitrous systems put a large demand on your vehicle's fuel system. Make sure you have a large enough fuel pump to handle the demands of your engine, as well as the nitrous system.

## Spark plugs and nitrous performance:

Quite often, wide-gap projected nose spark plugs will produce a detonation condition after a few seconds of nitrous use. The solution to the problem is to install spark plugs that have a colder heat range and proper ground strap design for nitrous use. Consult your preferred spark plug manufacturer to ensure you install the correct plugs for the nitrous level you choose to run.

## How to adjust power levels:

The ZEX™ Dual Perimeter Plate Nitrous System is designed for multiple power levels. These levels are controlled by metering jets installed in the two plate's fuel and nitrous jet fittings. To change the power output, all you need to do is install the appropriate set of jets as shown in Fig. 6. The correct combination of jets is listed on the tune-up sheet towards the end of this instruction manual.

# Installation Instructions

## Step 1:

### Decide where to put everything

Before you start to install the various components of this kit, you'll have to locate the best locations of each component by trial fitment and careful measurement. First, decide where you want to mount the nitrous and fuel solenoids. Remember, the stainless steel braided lines that connect these to the injection plate are 12 inches long. You'll also have to decide where to install the arming switch and the nitrous bottle. The arming switch should be installed in a position convenient to the driver, but not in an area that would increase the chances of unintentionally arming the system. To help you decide where and how you'll mount the nitrous supply bottle, check Fig. 1, 2, 3, and 4 for technical restrictions on bottle mounting locations and positions. Finally, have a reputable performance shop fill your nitrous bottle with automotive grade nitrous oxide before you begin. Do not overfill the nitrous bottle.

## Step 2:

### Mount Nitrous Supply Bottle

1. Mount the nitrous supply bottle with the outlet facing down. You may want to consider installing in a safety blow-down tube (ZEX™ Part # 82099), as most racetracks require one. Route the tube from the safety pressure relief cap to the exterior of the vehicle. Doing so will prevent your vehicle from filling with a cloud of nitrous oxide should the safety pressure relief cap rupture (Fig. 1).

2. Index the pickup tube with bottle position (Refer to Fig. 2, 3, and 4). ZEX™ nitrous bottles are designed with the bottom of the siphon tube at the

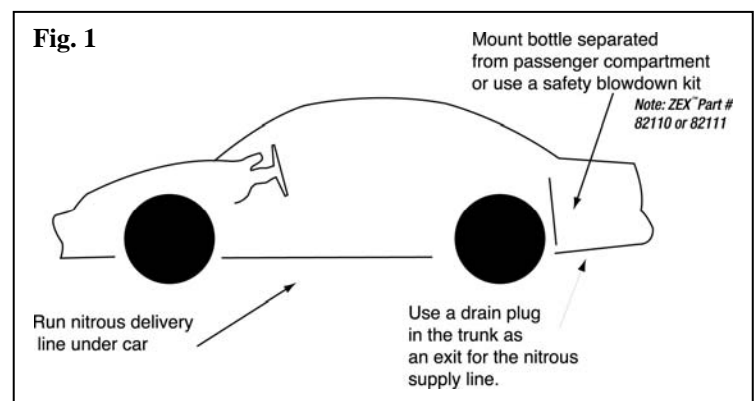

bottom of the bottle towards the outlet. Always mount the bottle so that as your vehicle accelerates, the liquid flows toward the pickup tube.

### Step 3:

#### Mount Nitrous Delivery Line Under the Car

When routing the nitrous delivery line under the vehicle, try to use the subframe as a conduit. This protects the line and eliminates the need to use clamps. The supplied cable ties work if you can run the line higher in the under-body so that it's safe from road level obstacles. For the pro-race look, you can use steel loom clamps with rubber sheathing to fasten the line to the body.

### Step 4:

#### Install Injector Plate

1. Remove the air cleaners.
2. Disconnect the throttle linkages.
3. Disconnect the fuel lines. Be sure to avoid spilling fuel on the engine.
4. Remove the carburetors and old carb gaskets, taking special note of all vacuum lines and choke linkages. Place a rag over the openings of the intake manifold to ensure that no debris or loose components get accidentally dropped into the engine during installation.
5. Remove the original carb studs and install the extended studs that are included with the kit.
6. Place the carb gaskets that are supplied with the nitrous kit on the manifold's carb. flanges. Place the nitrous plates on top of them, ensuring they are right side up. Place the remaining two carb. gaskets on top of the plates.
7. Install the 1/8 NPT tee fittings into the outlets of the nitrous and fuel solenoids (Fig. 7 and 8).
8. Install the 12" long -4 AN hose assemblies (4 total), with the male 1/8 NPT ends, into the outlets of the tee fittings for both the nitrous and fuel solenoids.
7. Install the -4AN filter fitting into the inlet of the nitrous solenoid. Install the 3/8 hose barb into the fuel solenoid inlet. Finally, install a solenoid bracket to the bottom of each of the solenoids using the button head allen screws included in the kit (see Fig. 7 and Fig. 8).
8. Select the appropriate nitrous and fuel jets, for the desired horsepower level, and insert them into the jet fittings in the end of the Perimeter Plate. Attach the appropriate lines from the nitrous and fuel solenoids to the jet fittings in the plate (see Fig. 6). Using a backing wrench, tighten the hoses to the jet fitting.
9. Remove one of the intake manifold bolts from each side of the engine and use it to fasten the fuel and nitrous solenoid brackets to the engine.
10. Attach the nitrous delivery line, from the bottle, to the nitrous solenoid.

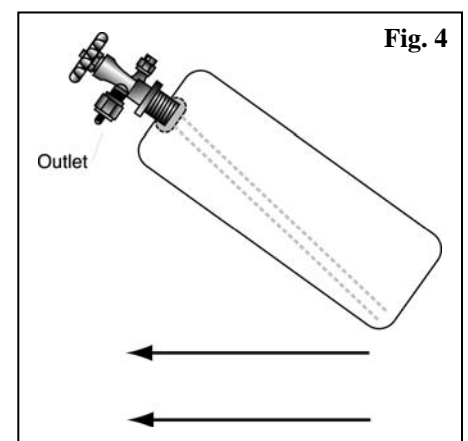
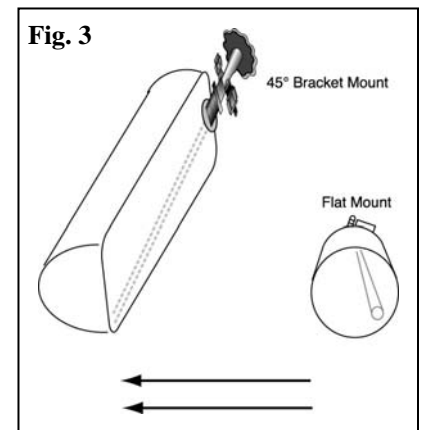
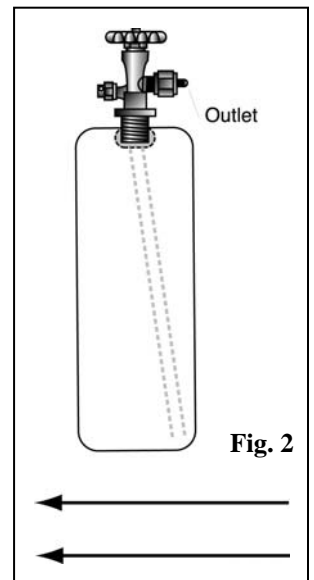

14. Connect the fuel solenoid inlet to a filtered source of pressurized fuel. 6 psi of flowing fuel pressure is required at the inlet of the fuel solenoid for a correct and safe tune-up.

15. Reinstall the carburetors, throttle linkages, vacuum lines, and choke linkages.

## Step 5: Wiring

1. Mount the arming switch in an easily accessible area for the driver.

2. Assemble the throttle switch to the throttle switch bracket using the 4-40 bolts and nylon lock nuts (see Fig. 5). Do not over tighten the bolts; damage to the throttle switch can result.

3. The throttle switch bracket is made of easily formed material. Attach the end of the bracket to one of the carb studs and bend the bracket in such a way to allow one of the carburetor's throttle arms to contact and depress the switch arm at wide open throttle.

4. Using the supplied electrical connectors and wire, refer to the wiring diagram for proper routing and electrical connections for the nitrous system (see Fig. 9). Always use the supplied fuse for electrical system protection in the event of a short in the system. The best positive (+) power source for the nitrous system is a direct connection to the battery's positive (+) post. Do not splice into the factory wire harness, it will not have the ability to supply the current required by the nitrous and fuel solenoids.

## Step 6: Check Fuel and Nitrous Pressure Lines

1. Perform a final inspection of all plumbing and electrical connections to ensure that they are correct.

2. Turn the arming switch to the ON position.

3. Depress the throttle switch and listen for both solenoids to click. If they both do not click, locate the problem and correct it before proceeding.

4. Start the engine and observe all fuel connections for any leaks. Fix any fuel leaks before proceeding.

5. Adjust the fuel pressure going to the inlet of the nitrous system's fuel solenoid to 6 psi flowing. Make sure you use a flowing fuel pressure tool to set the fuel pressure. Setting a "dead-head" style regulator in a non-flowing condition will not give you an accurate fuel pressure setting.

Fig. 5

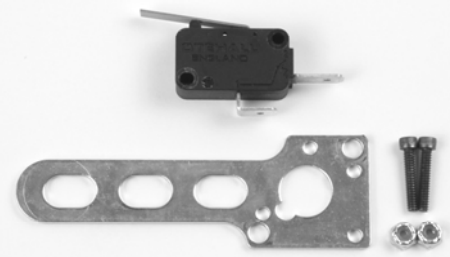

Fig. 6

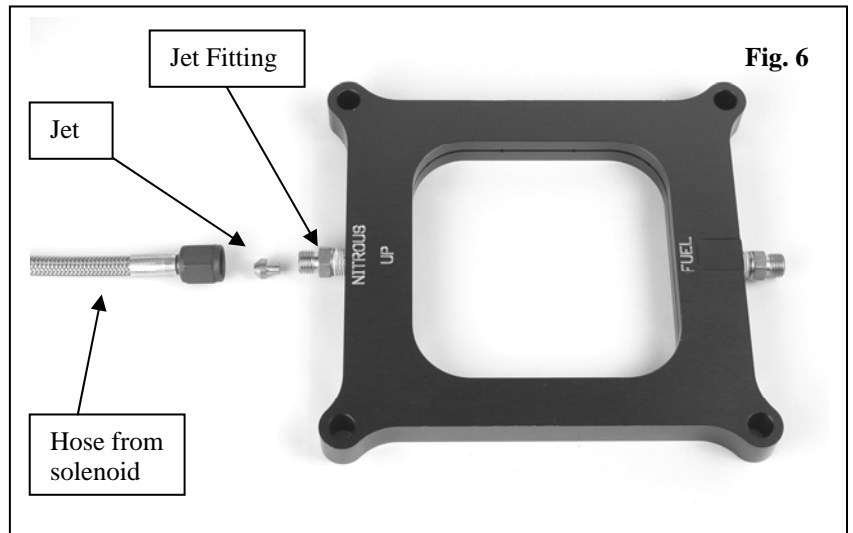

Fig. 7



Fig. 8



Severe engine damage can occur if care is not taken to ensure the correct fuel pressure at the solenoid.

6. Turn off the engine.

7. Open the nitrous bottle valve. Listen carefully for any leaks as your valve is opened. Leaks in the nitrous supply line will be obvious because they will be covered in frost.

8. If everything checks out, close the nitrous bottle and relieve the line pressure.

### **Step 7:**

#### **Reinstall your Air Cleaner**

### **Step 8:**

#### **Check Fuel Quality & Ignition Timing**

The last thing to do before enjoying your new nitrous system is to ensure that you have the correct fuel in the tank and your ignition timing is set properly. Premium fuel (92 R/M Octane or better) is required for the 150hp jets, 200hp to 300hp jetting requires the use of racing fuel to prevent engine damaging detonation. Refer to the Tune-Up Specs at the end of this instruction sheet for all recommended ignition timing retard amounts. If the correct ignition timing settings are not used, severe engine damage may occur from detonation.

### **Step 9:**

#### **Enjoy!**

After everything has been checked over and properly set-up, turn on the nitrous bottle and enjoy your ZEX™ Nitrous System.

## **ZEX™ #82185 Nitrous System Tune-Up Specs**

	<b>150hp</b>	<b>200hp</b>	<b>250hp</b>	<b>300hp</b>
<b>Nitrous Jet (950psi)</b>	46	56	64	105
<b>Fuel Jet (6psi)</b>	43	46	53	67
<b>Ignition Retard</b>	6deg	8deg	10deg	12deg

For engines less than 10-1 compression ratio, using nitrous system settings of 150hp or less, pump premium fuel is required for safe operation of your ZEX™ Nitrous System. For engines with 10-1 compression ratio or greater, using nitrous system settings higher than 150hp, high octane racing fuel is required for safe operation of your ZEX™ Nitrous System. Nitrous system fuel pressure must be set at 6psi, flowing, at the inlet of the fuel solenoid.

Fig. 9

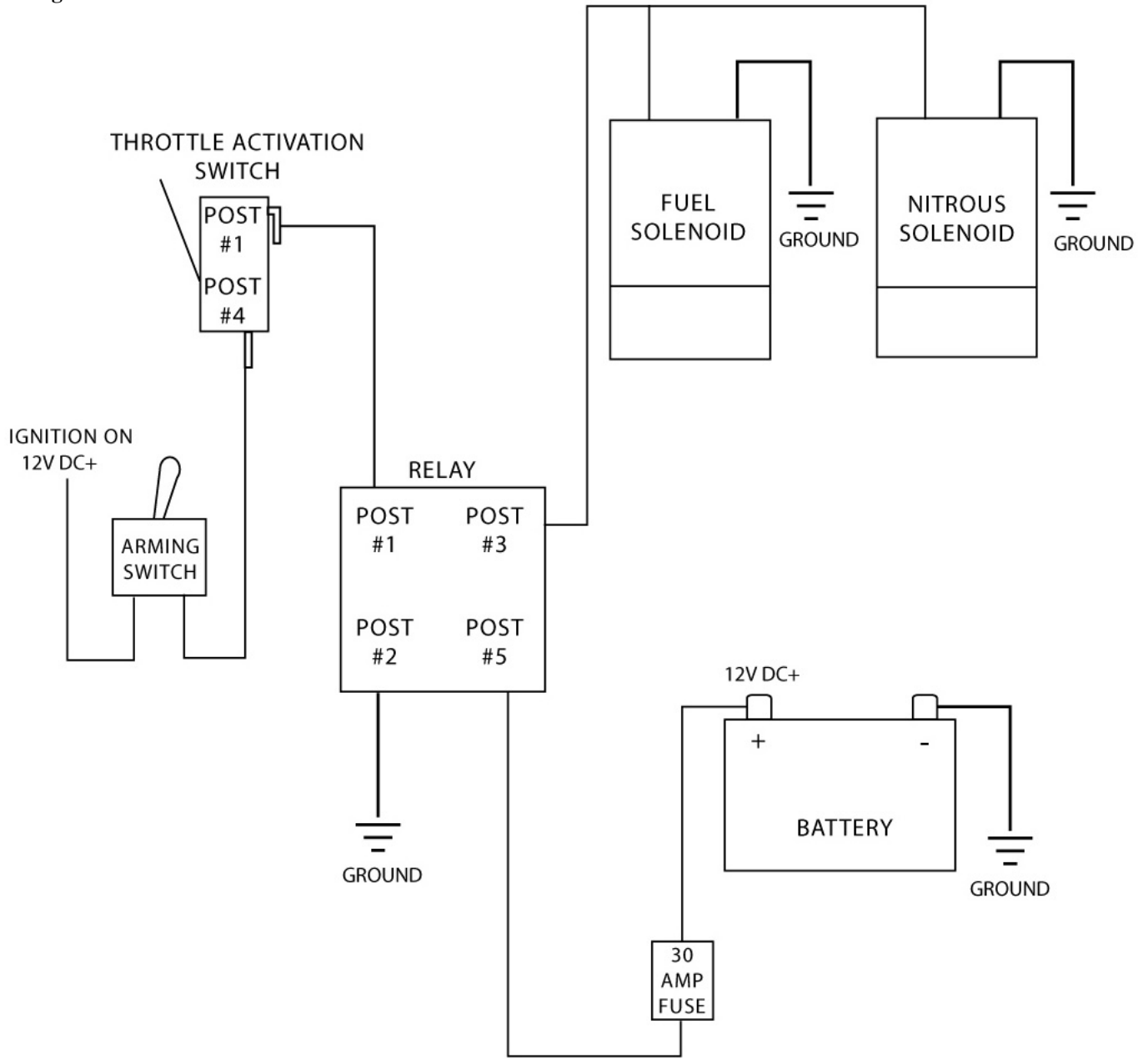

3418 Democrat Road

Memphis, TN, 38118

1-888-817-1008